

E-CUBE MOBILE 250G

SPECS:

Capacity (Gallons)	250
Length (inches)	61"
Width (inches)	40"
Height (inches)	42"
Weight Empty (lbs)	1410
Weight with Fuel (lbs)	3296
Inner Tank Thickness (in)	11/64"
Safe Fuel Fill Level	238
Outer Tank Thickness (base)	11/64"
Inner Tank Thickness (sidewall)	1/8"

* Calculations are based on safe fill levels at 95% total tank capacity & specific gravity of diesel as 0.9.

PRIMARY: 3" fusible fill cap, 2" pressure vacuum vent, standard breather vent, 3x1 1/4" feed.

Fitting Plate: sockets, 3x1" return sockets, float level fuel gauge.

SECONDARY:

Fitting Plate: Supplied with blank plate as standard, optional return & feed sockets available.

APPROVALS & CERTIFICATIONS

- UL-142 / UL-S601
- UN31 A/Y US D.O.T
- (IBC) Intermediate Bulk Container
- Lifting when Full Certified
- Vibration Tested



Design Features:

- Bi-directional forklift plates, internal baffle plates, galvanized hatch plates, stacking corners & lifting lugs to allow safe & easy handling
- Designed to stack inside shipping containers & across truck beds providing economical transportation
- Unique Hexagonal corners for extra strength
- Large designed dispensing gun equipment compartment with fixed arrangements to carry hose reels, pumps, gun nozzles, cables, batteries & bund alarms
- 110% bunded tank capacity – to meet the global environmental regulations
- Completely removable inner tank for easy maintenance & cleaning
- Primary & secondary hatch plates – for multiple use & versatility. (The primary hatch plates act as a manway)
- Space efficient design – easily stacked 2 high when full & 3 high when empty
- Unique pitched outer lid – designed to allow for dust & rain regress
- The primary hatch plate comes with a secure lockable design & has beading around the lid closing position
- The primary hatch plate is fitted with a 3" fill pipe, three- 1" return pipes & three- 1 1/4" feed pipes as standard for multiple use
- Tank has a unique extra large secondary hatch lid opening

E-Cube Mobile tanks are DOT Certified from E-Cube Mobile 125G to 792G, and are UN31A/Y—Certified to haul diesel UN1202 by road. E-Cube Mobile tanks are UL-142 & ULC S605 certified.

Features Overview

STANDARD FEATURES:

- Primary Hatch Plate
- Stacking Corner & Lifting Eye
- Universal Pump Bracket

OPTIONAL FEATURES:



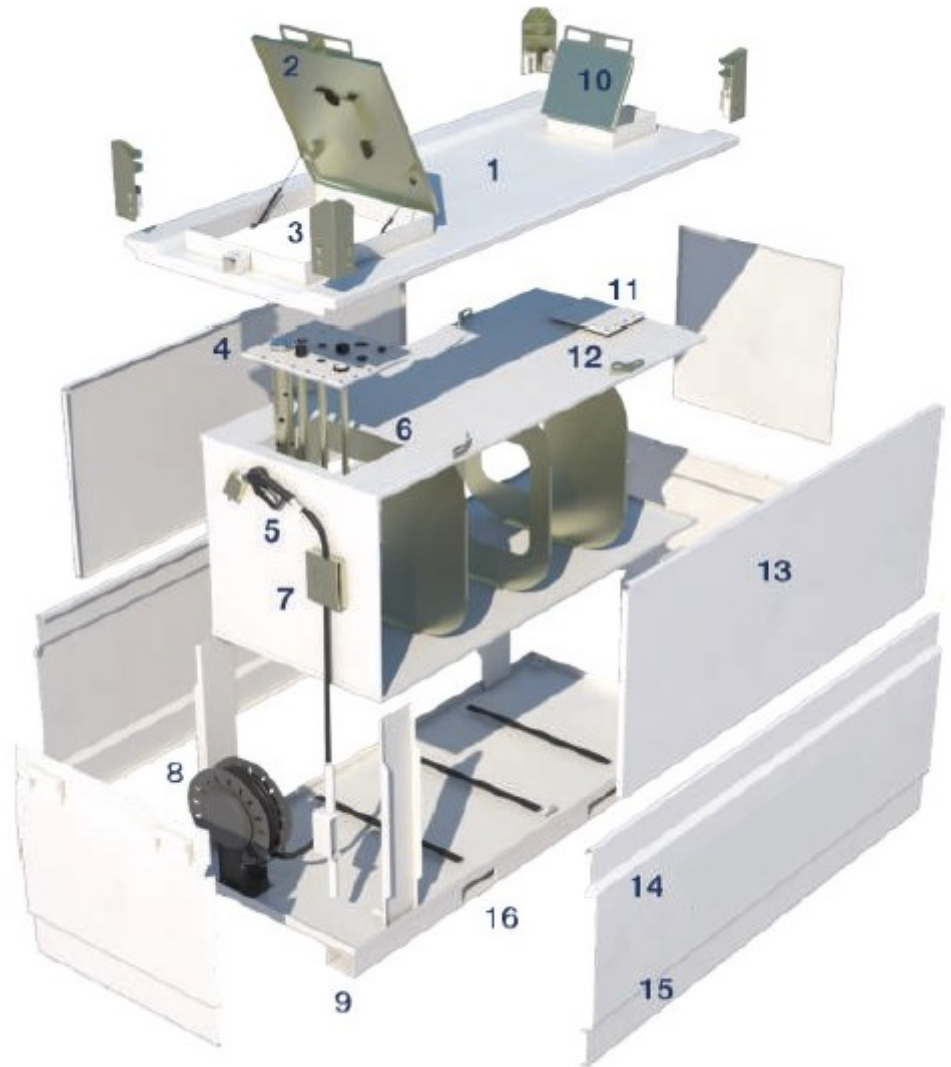





- Dispensing Nozzles
- Electric Pumps



1. External Lid
2. Primary Hatch Cover Lid
3. Stacking Cover with Lifting Lugs
4. Primary Hatch Fittings Plate
5. Bracket for Dispensing Nozzle
6. Internal Steel Fuel Pipes
7. Pump Bracket System
8. Hose Reel Brackets
9. Forklift Access
10. Secondary Hatch Cover Lid
11. Secondary Hatch Fittings Plate (fitting optional, extra)
12. Inner Primary Tank Lifting Lug
13. Inner Primary Tank
14. External Bund Tank
15. Skid Mounted Base Frame
16. Bi-Directional Forklift Pockets

[VIEW VIDEO](#)

Components and Functions

PRIMARY FITTING PLATE			SECONDARY FITTING PLATE		
			 <p>Standard</p>	 <p>Optional</p>	
 <p>Fuel Fill</p>	 <p>Fuel Return</p>	 <p>Pressure Vent</p>	 <p>Fuel Level Gauge</p>	 <p>Suction</p>	 <p>Emergency Vent</p>

Inner Tank: The inner tank is a primary storage tank having all fuel transfer accessories and externally encased within an outer bund tank.

Outer Tank: Outer bund designed to contain 110% on the inner tank volume it surrounds & wraps the main inner tank unit, has the interstitial space between inner & outer tanks. Therefore any potential leak that may occur will be captured in this sealed space, preventing the release to the environment.

Top Lid: The top plate used to cover the inner tank.

Fuel Fill: Fuel fill inlet used to fill the inner fuel tank in a secure way, without sparks and spillages. Automatic or manual latch nozzles can be used for filling.

Fuel Suction: Feeding of the engine (through a pump). Fuel suction pipe provided up to the level of 4" above from the bottom of the inner tank is used to withdraw fuel from the inner tank to the outlet unit (Genset/Engines). There are 2 suction points provided to feed the 2 units (Gensets/Engines) at the same time.

Fuel Return: Used as a return inlet for the excess fuel withdrawn from the tank. Normal Vent: Used to relieve vacuum and pressure of fuel as it expands and contracts.

Emergency Vent: Emergency vents are installed on aboveground storage tanks as a code requirement. Emergency vents provide high capacity pressure relief if the tank is exposed to fire. When the internal tank pressure reaches the opening pressure of the emergency vent, the weighted cover moves up on the center pin allowing air to escape. When the internal tank pressure falls, the cover automatically lowers back.

Fuel Level gauge: A fuel gauge is used to indicate the level of fuel contained in a tank. To measure or evaluate the remaining quantity of fuel in the tank.

Note: Over-fill provision can be provided as per client request.

Pump Kit: The pump kit takes the fuel from the day tank and uniformly flows the fuel to the required portable units with control of flow capacity.