

NOTES:

1. DIESEL USE
2. ENVIROLASTIC 940 DTM POLYASPARTIC URETHANE COATING FOR HIGH PERFORMANCE FINISH (MEMCO GREY)
3. UL 2085 LABELED AND LISTED
4. 2 HOUR RATING TESTED TO SWRI 97-04 NFPA 30 A FIRE RESISTANT TANK
5. ENGINEERED HURRICANE TIE-DOWN
6. LEAD TIME IS DEPENDENT ON IMMEDIATE APPROVAL

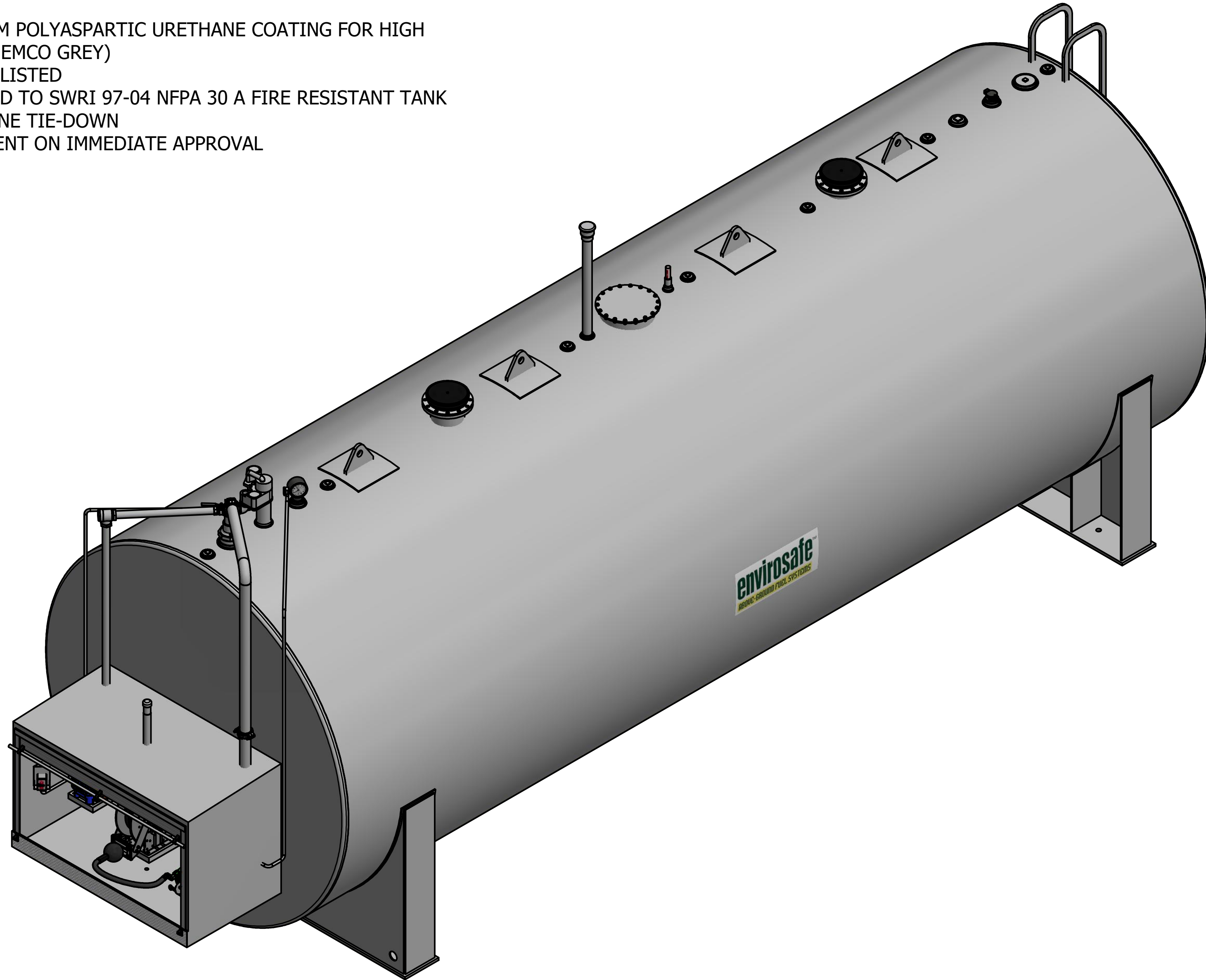

IT IS THE CLIENT'S RESPONSIBILITY TO ENSURE SYSTEM COMPLIANCE WITH APPLICABLE REGULATIONS.

LEAD TIMES BEGIN UPON RECEIPT OF SIGNED APPROVED DRAWING, WHICH MUST BE RETURNED BEFORE PRODUCTION CAN BEGIN

#

STI
SwRI
UL

This document and all information and design thereon are the property of Envirosafe Fuel Systems. This document is confidential and must not be made public or copied without written authorization from Envirosafe and is subject to return upon demand. No use of this document or any design thereon is permitted except as is specifically authorized in writing by Envirosafe. Acceptance of possession of this document constitutes full agreement with the above conditions. All Rights Reserved. Memco, Inc

DRAWN BY AP	3/12/2020	MEMCO, INC	
MEMCO REP		 20,000 GALLON FIREGUARD COMMERCIAL FLEET SYSTEM	
QUOTE #			
Customer Approval Signature		SIZE C	DWG NO
CUSTOMER REQUESTED COMPLETION DATE :		SCALE	REV
		SHEET 1 OF 5	

PARTS LIST			PARTS LIST		
ITEM	QTY	DESCRIPTION	ITEM	QTY	DESCRIPTION
1	1	20,000 GALLON FIREGUARD TANK MOUNTED ON SADDLES	15	1	FE PETRO 3/4 HP w/RISER, 88IN - 149IN (240V 1 PH)
2	1	18" MANWAY FOR EASY INNER TANK ACCESSIBILITY	16	1	TOTAL CONTROL 682-15 PISTON METER WITH 10:1 PULSER
3	2	6 IN NPT THREADED FLANGE	17	1	CIM-TEK 1 1/2" FILTER ADAPTER, 1" SPIN-ON FILTER
4	4	4 IN NPT THREADED FLANGE	18	1	VALVE BALL 1-1/2IN
5	7	3" NPT THREADED FLANGE (CONCRETE PORT)	19	1	VALVE BALL 2IN
6	1	3 IN NPT THREADED FLANGE	20	1	2" ANTI-SIPHON VALVE
7	2	2 IN NPT THREADED FLANGE	21	1	PUMP SWITCH, COVER & BACKPLATE, 1/2" EXPLOSION PROOF BOX
8	4	LIFTING LUG	22	1	REEL HOSE N800 1" SPRING REEL INLET RIGHT WITH 1"x25' HOSE PUMPFLEX II, 1"x12" HOSE WHIP, 1" BREAKAWAY, 1" NOZZLE, 1" SWIVEL
9	2	10" 8OZ EMERGENCY VENT FLANGED	23	1	MONITORING CAP 2"
10	1	3" UPDRAFT STACK W/3" 354 SLIP ON	24	1	STEP LADDER WITH SAFETY SHIELD
11	1	3" OVERFILL PREVENTION VALVE WITH TEST MECHANISM AND DIFFUSER	25	1	INTERSTITIAL LEAK GAUGE
12	1	UL LISTED LOCKABLE FILL BOX 3'6" X 6'6" X 4'2" CROSS BROKEN FOR EASY DRAINAGE, 2" VENT, MUSHROOM CAP, 1/2 BALL VLAVE	26	1	TANK DECAL KIT (NOT SHOWN)
13	1	3" GROUND LEVEL FILL WITH DUST CAP AND ADAPTOR	27	6	1" REPLACEMENT FILTERS (NOT SHOWN AND SHIPPED SEPARATELY)
14	1	918 CLOCK GAUGE WITH ALARM BOX & STANDARD FLOAT	28	1	TOUCH UP PAINT (NOT SHOWN AND SHIPPED SEPARATELY)

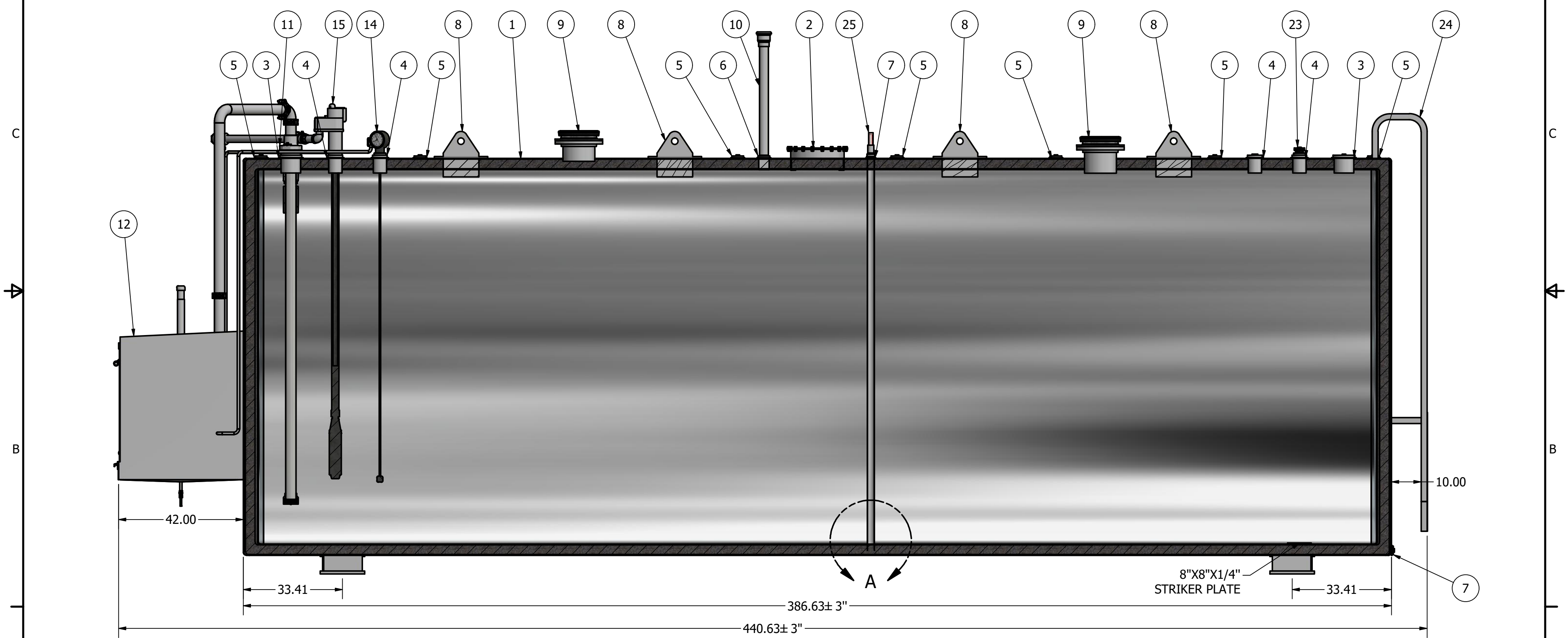
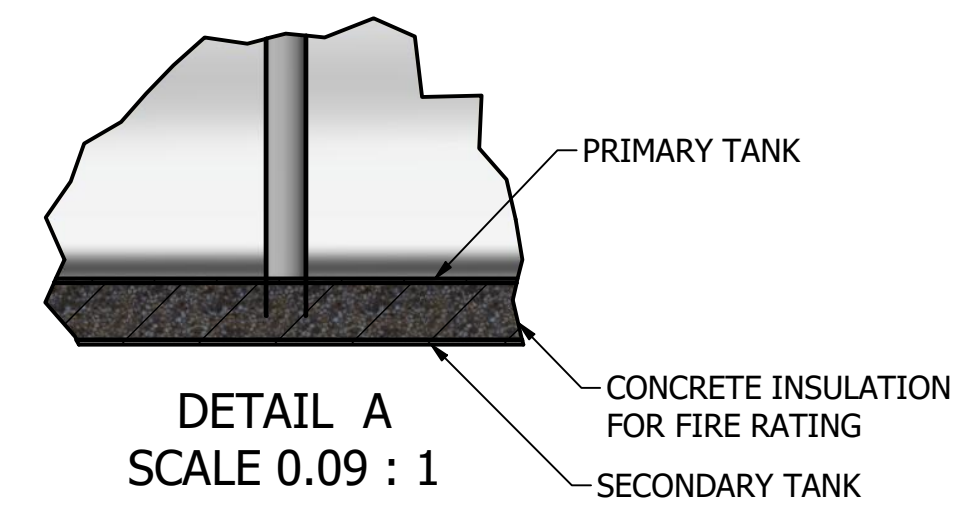

IT IS THE CLIENT'S RESPONSIBILITY TO ENSURE SYSTEM COMPLIANCE WITH APPLICABLE REGULATIONS.

LEAD TIMES BEGIN UPON RECEIPT OF SIGNED APPROVED DRAWING, WHICH MUST BE RETURNED BEFORE PRODUCTION CAN BEGIN #

SHELL THICKNESS: 5/16"
HEAD THICKNESS: 5/16"
STI
SwRI
UL

DRAWN BY AP	3/12/2020	MEMCO, INC	
MEMCO REP			
QUOTE #		 20,000 GALLON FIREGUARD COMMERCIAL FLEET SYSTEM <small>ABOVE-GROUND FUEL SYSTEMS</small>	
Customer Approval Signature			
SIZE C	DWG NO	REV	
SCALE	SHEET 2 OF 5		

This document and all information and design thereon are the property of Envirosafe Fuel Systems. This document is confidential and must not be made public or copied without written authorization from Envirosafe and is subject to return upon demand. No use of this document or any design thereon is permitted except as is specifically authorized in writing by Envirosafe. Acceptance of possession of this document constitutes full agreement with the above conditions. All Rights Reserved. Memco, Inc

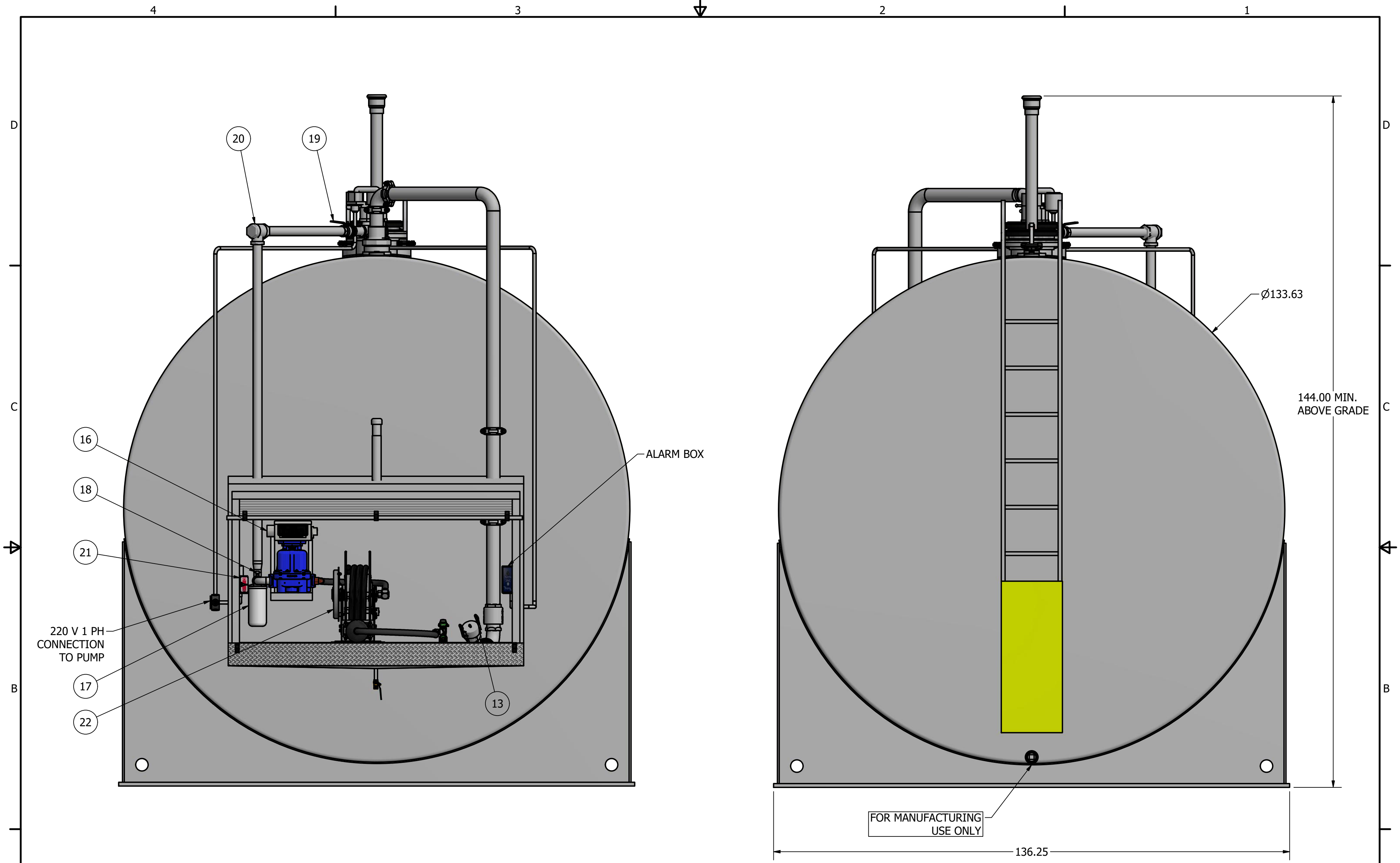

LEAD TIMES BEGIN UPON RECEIPT OF SIGNED APPROVED DRAWING, WHICH MUST BE RETURNED BEFORE PRODUCTION CAN BEGIN #

This document and all information and design thereon are the property of Envirosafe Fuel Systems. This document is confidential and must not be made public or copied without written authorization from Envirosafe and is subject to return upon demand. No use of this document or any design thereon is permitted except as is specifically authorized in writing by Envirosafe. Acceptance of possession of this document constitutes full agreement with the above conditions. All Rights Reserved. Memco, Inc

STI
SwRI
UL

IT IS THE CLIENT'S RESPONSIBILITY TO ENSURE SYSTEM COMPLIANCE WITH APPLICABLE REGULATIONS.

DRAWN BY AP		3/12/2020		MEMCO, INC	
MEMCO REP					
QUOTE #				 20,000 GALLON FIREGUARD COMMERCIAL FLEET SYSTEM <small>ABOVE-GROUND FUEL SYSTEMS</small>	
Customer Approval Signature					
SIZE C	DWG NO			REV	
SCALE				SHEET 3 OF 5	